



**PUDUCHERRY SMART CITY DEVELOPMENT LIMITED
(GOVERNMENT OF PUDUCHERRY UNDERTAKING)**

**NAME OF WORK: PROVIDING & FIXING DECORATIVE LED LIGHTING
FROM KARGIL WAR MEMORIAL TO NORTHERN REEF
AND DUPLEX STATUE TO PIER (OLD PORT) OF
BEACH PROMENADE IN PUDUCHERRY.**

NOTICE INVITING TENDER

(THROUGH e-TENDER MODE)

FORM – 6

Certified that this NIT contains 19 items serially
numbered from 1 to 19

This NIT contains 56 pages and approved for an amount of
₹ 11,85,900/-
(Rupees Eleven lakhs eighty five thousand and nine hundred only)

NOTICE INVITING TENDER

Tender for the work of : Providing & Fixing decorative LED lighting from Kargil War Memorial to Northern Reef and Duplex Statue to pier (old port) of Beach Promenade in Puducherry.

Approximate cost put to Tender : ₹ 11,85,900/-

Earnest Money Deposit : ₹ 23,718/-
(to be returned after receiving PG)

Date of Tender : 24.02.2021

This tender contains : 56 pages

Time allowed for the work : 2 months (including monsoon period)

**CHIEF EXECUTIVE OFFICER
PSCDL, PUDUCHERRY**

**PUDUCHERRY SMART CITY DEVELOPMENT LIMITED
(GOVERNMENT OF PUDUCHERRY UNDERTAKING)**

NOTICE INVITING TENDER for e-Tendering

1. ~~Percentage~~/ Item rate tenders are invited on behalf of the Puducherry Smart City Development Limited from eligible contractors / firms for the work of **“Providing & Fixing Decorative LED Lighting from Kargil War Memorial to Northern Reef and Duplex Statue to Pier (Old Port) of Beach Promenade in Puducherry.”** through e-Tender in online.

1.1 The work is estimated to cost **₹ 11,85,900/-** This estimate, however, is given merely as a rough guide.

The enlistment of the contractors should be valid on the last date of submission of tenders.

In case the last date of submission of tender is extended, the enlistment of contractors should be valid on the original date of submission of tenders.

1.2 Tender can be downloaded from e-Tender website www.pudutenders.gov.in by the eligible contractors/firms. The Contractors those who registered in Electricity Dept., Puducherry (Grade B & above) is eligible to participate in this tender.

Contractors other than those registered in Electricity Dept, Puducherry should produce definite proof from the appropriate authority, ~~which shall be to the satisfaction of the competent authority of having satisfactorily completed similar works of magnitude specified below during the last 7 years ending previous day of last date of submission of tenders.~~

~~For the purpose of this clause “Similar works” means the works of “Granite Works”.~~

~~1.2.1 Conditions for Non Puducherry P.W.D contractors only~~

~~Three similar completed works costing not less than 40% of the estimated cost put to tender~~

~~(OR)~~

~~Two similar completed works costing not less than 60% of the estimated cost put to tender~~

~~(OR)~~

~~One similar completed work costing not less than 80% of the estimated cost put to tender~~

~~The value of executed works shall be brought to current costing level by enhancing the actual value of work at simple rate of 7% per annum; calculated from the date of completion to last date of submission of tenders.~~

~~1.2.2 To become eligible for issue of tender, the tenderers shall have to furnish an affidavit as under:~~

~~I/We undertake and confirm that eligible similar work(s) has/have not been got executed through another contractor on back to back basis. Further that, if such a violation comes to the notice of Puducherry Smart City Development Limited, then I/we shall be debarred for tendering in Puducherry Smart City Development Limited in future forever. Also, if such a violation comes to the notice of Puducherry Smart City Development Limited before date of start of work, the Chief Executive Officer shall be free to forfeit the entire amount of Earnest Money Deposit/Performance Guarantee. (Scanned copy to be uploaded at the time of submission of tender)~~

~~1.2.3~~ ~~When tenders are invited from non Puducherry Public Works Department contractors as per provisions of clause 1.2.1 above, it will be mandatory for non P.W.D contractors to upload the work experience certificate(s) and the affidavit as per the provisions of clause. **Particulars of completed works for fulfilling the eligibility criteria duly authenticated / certified by an officer not below the rank of Executive Engineer or equivalent in Government Organisation** be furnished separately for each completed work.~~

~~1.2.4.~~ ~~But for such tenders, registered contractors of Public Works Department in Puducherry are eligible to submit the tenders without submission of work experience certificate and affidavit. Therefore, Puducherry Public Works Department registered contractors shall upload two separate letters for experience certificate and affidavit that these documents are not required to be submitted by them. Uploading of these two letters is mandatory otherwise system will not clear mandatory fields.~~

2. Agreement shall be drawn with the successful tenderers on prescribed Puducherry Smart City Development Limited Form No. **7/8**. Tenderer shall quote his rates as per various terms and conditions of the said form which will form part of the agreement.

3. The time allowed for carrying out the work will be **2 Months** (including monsoon period) from the date of start as defined in schedule 'F' or from the first date of handing over of the site, whichever is later, in accordance with the phasing, if any, indicated in the tender documents.

4. (i) ~~The site for the work is available.~~

OR

The site for the work shall be made available in parts as per execution of work:

~~(ii) The architectural and structural drawing for the work is available~~

OR

~~The architectural and structural drawings shall be made available in phased manner, as per requirement of the same as per approved programme of completion submitted by the contractor after award of work.~~

5. The tender document consisting of plans, specifications, the schedule of quantities of various types of items to be executed and the set of terms and conditions of the contract to be complied with and other necessary documents except Standard General Conditions of Contract Form can be seen on website www.pudutenders.gov.in at free of cost.

6. After submission of the tender the contractor can re-submit revised tender any number of times but before last time and date of submission of tender as notified.

7. While submitting the revised tender, contractor can revise the rate of one or more item(s) any number of times (he need not re-enter rate of all the items) but before last time and date of submission of tender as notified.

8. When tenders are invited in three stage system and if it is desired to submit revised financial tender then it shall be mandatory to submit revised financial tender. If not submitted then the tender submitted earlier shall become invalid.

9. Tenders shall be accompanied with Earnest money of ₹ 23,718/- in cash (upto ~~₹ 10,000/-~~) through DIRECT DEBIT / NEFT / RTGS mode only through online in favour of the Chief Executive Officer, Puducherry Smart City Development Limited, for which necessary challan will be available in the website.

~~A part of earnest money is acceptable in the form of bank guarantee also, when the amount of Earnest money is more than ₹ 5.00 Lakhs.~~

~~In such case minimum 50% of EMD or ₹ 20.00 Lakhs whichever is less will have to be deposited in shape prescribed above and balance amount of earnest money can be accepted in the form of Bank Guarantee issued by the scheduled bank having validity for 6 months or more from the last date of receipt of tenders which is to be scanned and uploaded by the intending tenderers and the successful tenderer shall extend the validity of such Bank guarantee for the period of completion plus 12 months maintenance period.~~

~~The physical Bank Guarantee for part of the EMD of the scanned copy uploaded shall be deposited by the lowest tenderer within a week after opening of financial tender failing which the tender shall be rejected.~~

The following undertaking in this regard shall also be uploaded by the intending tenderers:-

~~“The Physical Bank Guarantee for part of the EMD shall be deposited by me/us with the Chief Executive Officer calling the tender in case I/we become the lowest tenderer within a week of the opening of financial tender otherwise Puducherry Smart City Development Limited may reject the tender and also take action to withdraw my/our enlistment/debar me/us from tendering in Puducherry Smart City Development Limited~~

Interested contractor who wish to participate in the tender has also to make following payments within the period of tender submission:

e-tender processing fee - ₹ 500/- + 5% GST (non-refundable) shall be payable using payment e-gateway of ICICI Bank through internet banking or RTGS/NEFT facility drawn in favour of **the Chief Executive Officer, Puducherry Smart City Development Limited, Puducherry.**

Copy of the Electrical grade registration certificate and other documents as specified in the press notice including GST registration certificate shall be scanned and uploaded to the e-Tendering website within the period of tender submission. However, certified copy of all the scanned and uploaded documents as specified in press notice shall have to be submitted by the lowest tenderer ~~only along with physical Bank Guarantee for part of the EMD of the scanned copy of EMD uploaded~~ within a week physically in the office of tender opening authority.

Online tender documents submitted by intending tenderers shall be opened only of those tenderers, who has deposited e-Tender Processing Fee and Earnest Money Deposit through the payment gateway provided on e-tender portal <https://pudutenders.gov.in> and other documents scanned and uploaded are found in order.

The tender submitted shall be opened at 11.00 AM on 24.02.2021

10. The tender submitted shall become invalid and e-tender processing fee shall not be refunded if:

- (i) The tenderer is found ineligible.
- (ii) The tenderer does not upload all the documents (including GST registration) as stipulated in the tender document ~~including the undertaking about deposition of physical EMD of the scanned copy of EMD uploaded.~~
- (iii) If any discrepancy is noticed between the documents as uploaded at the time of submission of tender and hard copies as submitted *physically by the lowest tenderer* in the office of tender opening authority.

(iv) ~~If part of the EMD drawn in the form of Bank Guarantee the contractor should upload the scanned copy of the same. The physical Bank Guarantee shall be deposited by the lowest tenderer with in a week after opening of financial tender failing which the tender shall be rejected.~~

~~(v) The lowest tenderer does not deposit physical Bank Guarantee for part of the EMD within a week of opening of tender.~~

11. The contractor whose tender is accepted will be required to furnish performance guarantee of 5% (Five Percent) of the tender amount within the period specified in Schedule F. This guarantee shall be in the form of Banker's cheque of any scheduled bank/Demand Draft of any scheduled bank/ Term Deposit receipt/ Pay order of any Scheduled Bank or Government Securities or Fixed Deposit Receipts or Guarantee Bonds of any Scheduled Bank or the State Bank of India in accordance with the prescribed form. The earnest money deposited alongwith tender shall be returned after receiving the aforesaid performance guarantee.

(a) On evaluation of tender and if the tender is found that the overall amount quoted is **below 15.00% and more than below 15.00%** , then the contractor shall be asked to pay an additional performance guarantee amounting to 50% of the difference between the quoted amount and estimate cost put to tender. Failure to furnish the additional performance guarantee over and above the normal performance guarantee of 5% within the specified period from the date of receipt of acceptance letter, shall entitle cancellation of award and forfeiture of EMD furnished.

(b) This period can be further extended at the written request of the contractor by the Chief Executive Officer for a maximum period ranging from 1 to 15 days with late fee @ 0.1% per day, of performance guarantee amount.

In case the contractor fails to deposit the said performance guarantee and additional performance guarantee, if any, within the period as indicated in Schedule 'F', including the extended period if any, the Earnest Money deposited by the contractor shall be forfeited automatically without any notice to the contractor.

12. The description of the work is as follows:

“Providing & Fixing Decorative LED Lighting from Kargil War Memorial to Northern Reef and Duplex Statue to Pier (Old Port) of Beach Promenade in Puducherry”.

Intending Tenderers are advised to inspect and examine the site and its surroundings and satisfy themselves before submitting their tenders as to the nature of the ground and sub-soil (so far as is practicable), the form and nature of the site, the means of access to the site, the accommodation they may require and in general shall themselves obtain all necessary information as to risks, contingencies and other circumstances which may influence or affect their tender. A tenderer shall be deemed to have full knowledge of the site whether he inspects it or not and no extra charge consequent on any misunderstanding or otherwise shall be allowed. The tenderers shall be responsible for arranging and maintaining at

his own cost all materials, tools & plants, water, electricity access, facilities for workers and all other services required for executing the work unless otherwise specifically provided for in the contract documents. Submission of a tender by a tenderer implies that he has read this notice and all other contract documents and has made himself aware of the scope and specifications of the work to be done and of conditions and rates at which stores, tools and plant, etc. will be issued to him by the Puducherry Smart City Development Limited and local conditions and other factors having a bearing on the execution of the work.

13. The competent authority on behalf of the Puducherry Smart City Development Limited does not bind himself to accept the lowest or any other tender and reserves to himself the authority to reject any or all the tenders received without the assigning of any reason. All tenders in which any of the prescribed condition is not fulfilled or any condition including that of conditional rebate is put forth by the tenderers shall be summarily rejected.

14. Canvassing whether directly or indirectly, in connection with tenderers is strictly prohibited and the tenders submitted by the contractors who resort to canvassing will be liable for rejection.

15. The competent authority on behalf of Puducherry Smart City Development Limited reserves to himself the right of accepting the whole or any part of the tender and the tenderers shall be bound to perform the same at the rate quoted.

16. The contractor shall not be permitted to tender for works in the Puducherry Smart City Development Limited responsible for award and execution of contracts, in which his near relative is posted as an officer in any capacity. He shall also intimate the names of persons who are working with him in any capacity or are subsequently employed by him and who are near relatives as an officer in any capacity in the Puducherry Smart City Development Limited (PSCDL), Union Territory of Puducherry. Any breach of this condition by the contractor would render him liable to be removed.

17. No Engineer of Gazetted Rank or other Gazetted Officer employed in Engineering or Administrative duties in an Engineering Department of the Government of India is allowed to work as a contractor for a period of one year after his retirement from Government service, without the prior permission of the Government of India in writing. This contract is liable to be cancelled if either the contractor or any of his employees is found any time to be such a person who had not obtained the permission of the Government of India as aforesaid before submission of the tender or engagement in the contractor's service.

18. The tender for the works shall remain open for acceptance for a period of ~~thirty/ forty five/ sixty/ ninety (30/45/60/90) days from the date of opening of tenders in case of one bid system/~~**Ninety(90) days from the date of opening of technical bid in case bids are invited on 2 bid/envelop system/**~~One hundred twenty(120) days from the date of opening of technical~~

~~bid incase bids are invited on 3 bid/envelope system for specialized work~~ (strike out as the case may be). If any tenderers withdraws his tender before the said period or issue of letter of acceptance, whichever is earlier, or makes any modifications in the terms and conditions of the tender which are not acceptable to the Puducherry Smart City Development Limited, then the Puducherry Smart City Development Limited shall, without prejudice to any other right or remedy, be at liberty to forfeit 50% of the said earnest money as aforesaid. Further the tenderers shall not be allowed to participate in the rebidding process of the work.

19. This notice inviting Tender shall form a part of the contract document. The successful tenderers/contractor, on acceptance of his tender by the Accepting Authority shall within 15 days from the stipulated date of start of the work, sign the contract consisting of:-

- (a) The Notice Inviting Tender, all the documents including additional conditions, specifications and drawings, if any, forming part of the tender as uploaded at the time of invitation of tender and the rates quoted online at the time of submission of tender and acceptance thereof together with any correspondence leading thereto.
- (b) Standard PSCDL Form 7/8 or other Standard PSCDL Form as applicable.

20. The Chief Executive Officer, PSCDL, Puducherry may reserves the right to change the tender submission and opening date and time without assigning any reason by notifying the same in the website.

21. If the opening day of tender happens to be a Public Holiday the same will be opened on next working day.

**PUDUCHERRY SMART CITY DEVELOPMENT LIMITED
(GOVERNMENT OF PUDUCHERRY UNDERTAKING)**

STATE : PUDUCHERRY

REGION : PUDUCHERRY

~~Percentage Rate Tender/Item Rate Tender & Contract for Works~~

(A) Tender for the work of:-

“Providing & Fixing Decorative LED Lighting from Kargil War Memorial to Northern Reef and Duplex Statue to Pier (Old Port) of Beach Promenade in Puducherry”.

(i) To be submitted/uploaded from **4:00 PM on 18.02.2021 to 4:00 PM on 24.02.2021** / in www.pudutenders.gov.in

(ii) To be opened in presence of tenderers who may be present at **5:00 PM on 24.02.2021** in the office of Puducherry Smart City Development Limited.

Issued to:

Signature of officer issuing the documents

Designation:

Date of Issue:

* Not Applicable for
e-tendering

TENDER

I/We have read and examined the notice inviting tender, schedule, A, B, C, D, E & F Specifications applicable, Drawings & Designs, General Rules and Directions, Conditions of Contract, clauses of contract, Special conditions, Schedule of Rate & other documents and Rules referred to in the conditions of contract and all other contents in the tender document for the work.

I/We hereby tender for the execution of the work specified for the Chief Executive Officer, Puducherry Smart City Development Limited within the time specified in Schedule 'F' viz., schedule of quantities and in accordance in all respect with the specifications, designs, drawing and instructions in writing referred to in Rule-1 of General Rules and Directions and in Clause 11 of the Conditions of contract and with such materials as are provided for, by, and in respect of accordance with, such conditions so far as applicable.

We agree to keep the tender open for ~~thirty/ forty five/ sixty/ ninety (30/45/60/90) days from the due date of its opening in case of one bid system /~~ **Ninety(90) days from the date of opening of technical bid in case tenders are invited on 2 bid/envelope system/** ~~One hundred twenty(120) days from the date of opening of technical bid in case bids are invited on 3 bid/envelope system for specialised work (strike out as the case may be) and not to make any modification in its terms and conditions.~~

A sum of ₹ **23,718/-** is hereby forwarded in ~~cash (upto ₹ 10,000/-)~~ through DIRECT DEBIT / NEFT / RTGS mode through online as earnest money.

This tender is accompanied with a Earnest Money Deposited through DIRECT DEBIT / NEFT / RTGS mode through online in favour of the Chief Executive Officer, PSCDL ~~/bank guarantee issued by a scheduled bank is scanned and uploaded~~ (strike out as the case may be). If I/We, fail to furnish the prescribed performance guarantee within prescribed period, I/We agree that the said on behalf of the Puducherry Smart City Development Limited or his successors, in office shall without prejudice to any other right or remedy, be at liberty to forfeit the said earnest money absolutely. Further, if I/We fail to commence work as specified, I/ We agree that on behalf of the Chief Executive Officer, Puducherry Smart City Development Limited or the successors in office shall without prejudice to any other right or remedy available in law, be at liberty to forfeit the said performance guarantee absolutely. The said Performance Guarantee shall be a guarantee to execute all the works referred to in the tender documents upon the terms and conditions contained or referred to those in excess of that limit at the rates to be determined in accordance with the provision contained in Clause 12.2 and 12.3 of the tender form.

Further, I/We agree that in case of forfeiture of Earnest Money or Performance Guarantee as aforesaid, I/We shall be debarred for participation in the re-tendering process of the work.

I/We undertake and confirm that eligible similar work(s) has/have not been got executed through another contractor on back to back basis. Further that, if such a violation comes to the notice of Puducherry Smart City Development Limited, then I/We shall be debarred for tendering in Puducherry Smart City Development Limited in future forever. Also, if such a violation comes to the notice of Puducherry Smart City Development Limited before date of start of work, the Chief Executive Officer shall be free to forfeit the entire amount of Earnest Money Deposit/Performance Guarantee.

I/We hereby declare that I/We shall treat the tender documents drawings and other records connected with the work as secret/confidential documents and shall not communicate information/derived therefrom to any person other than a person to whom I/We am/are authorized to communicate the same or use the information in any manner prejudicial to the safety of the State.

Dated

Witness:

Address:

Occupation:

Signature of Contractor

Postal Address

A C C E P T A N C E

The above tender (as modified by you as provided in the letters mentioned hereunder) is accepted by me for and on behalf of the Puducherry Smart City Development Limited for a sum of Rs.....
(Rupees.....
.....
.....)

The letters referred to below shall form part of this contract agreement:-

- (a)

- (b)

- (c)

For & on behalf of the PSCDL

Signatures.....

Designation.....

Dated:

**PUDUCHERRY SMART CITY DEVELOPMENT LIMITED
(GOVERNMENT OF PUDUCHERRY UNDERTAKING)**

GENERAL RULES & DIRECTIONS:

1. All work proposed for execution by contract will be notified in a form of invitation to tender pasted in public places and signed by the officer inviting tender or by publication in News papers or posted on website as the case may be. This form will state the work to be carried out, as well as the date for submitting and opening tenders and the time allowed for carrying out the work, also the amount of earnest money to be deposited with the tender, and the amount of the security deposit and Performance guarantee to be deposited by the successful tenderer and the percentage, if any, to be deducted from bills. Copies of the specifications, designs and drawings and any other documents required in connection with the work signed for the purpose of identification by the officer inviting tender shall also be open for inspection by the contractor at the office of officer inviting tender during office hours.
2. In the event of the tender being submitted by a firm, it must be signed separately by each partner thereof or in the event of the absence of any partner, it must be signed on his behalf by a person holding a power-of attorney authorizing him to do so, such power of attorney to be produced with the tender, and it must disclose that the firm is duly registered under the Indian Partnership Act, 1952.
3. Receipts for payment made on account of work, when executed by a firm, must also be signed by all the partners, except where contractors are described in their tender as a firm, in which case the receipts must be signed in the name of the firm by one of the partners, or by some other person having due authority to give effectual receipts for the firm.

APPLICABLE FOR ITEM RATE TENDER ONLY

4. Any person who submits a tender shall fill up the usual printed form, stating at what rate he is willing to undertake each item of the work. Tenders, which propose any alteration in the work specified in the said form of invitation to tender, or in the time allowed for carrying out the work, or which contain any other conditions of any sort, including conditional rebates, will be summarily rejected. No single tender shall include more than one work, but contractors who wish to tender for two or more works shall submit separate tender for each. Tender shall have the name and number of the works to which they refer, written on the envelopes. The rate(s) must be quoted in decimal coinage. Amounts must be quoted in full rupees by ignoring fifty paise and considering more than fifty paise as rupee one. In case the lowest tendered amount (worked out on the basis of quoted rate of Individual items) of two or more contractors is same, then such lowest contractors may be asked to submit sealed revised offer quoting rate of each item of the schedule of quantity for all sub sections/sub heads as the case may be, but the revised quoted rate of each item of schedule of quantity for all sub sections/sub heads should not be higher than their respective original rate quoted already at the time of submission of tender. The lowest tender shall be decided on the basis of revised offer.

If the revised tendered amount (worked out on the basis of quoted rate of individual items) of two or more contractors received in revised offer is again found to be equal, then the lowest tender, among such contractors, shall be decided by draw of lots in the presence Chief Executive Officer, PSCDL and the lowest contractors those who have quoted equal amount of their tenders.

In case all the lowest contractors those who have same tendered amount (as a result of their quoted rate of individual items), refuse to submit revised offers, then tenders are to be recalled after forfeiting 50% of EMD of each lowest contractors.

Contractor, whose earnest money is forfeited because of non-submission of revised offer, or quoting higher revised rate(s) of any item(s) than their respective original rate quoted already at the time of submission of his tender shall not be allowed to participate in the retendering process of the work.

APPLICABLE FOR PERCENTAGE RATE TENDER ONLY

4.A. In case of Percentage Rate Tenders, contractor shall fill up the usual printed form, stating at what percentage below/above (in figures as well as in words) the total estimated cost given in Schedule of Quantities at Schedule-A, he will be willing to execute the work. The tender submitted shall be treated as invalid if-

1. The contractor does not quote percentage above/below on the total amount of tender or any section/sub head of the tender.
2. The percentage above/below is not quoted in figures & words both on the total amount of tender or any section/sub head of the tender.
3. The percentage quoted above/below is different in figures & words on the total amount of tender or any section/sub head of the tender.

Tenders, which propose any alteration in the work specified in the said form of invitation to tender, or in the time allowed for carrying out the work, or which contain any other conditions of any sort including conditional rebates, will be summarily rejected. No single tender shall include more than one work, but contractors who wish to tender for two or more works shall submit separate tender for each. Tender shall have the name and number of the works to which they refer, written on the envelopes.

4B. In case the lowest tendered amount (estimated cost \pm amount worked on the basis of percentage above/below) of two or more contractors is same, such lowest contractors will be asked to submit sealed revised offer in the form of letter mentioning percentage above/ below on estimated cost of tender including all sub sections/sub heads as the case may be, but the revised percentage quoted above/below on tendered cost or on each sub section/ sub head should not be higher than the percentage quoted at the time of submission of tender. The lowest tender shall be decided on the basis of revised offers.

In case any of such contractor refuses to submit revised offer, then it shall be treated as withdrawal of his tender before acceptance and 50% of earnest money shall be forfeited.

If the revised tendered amount of two more contractors received in revised offer is again found to be equal, the lowest tender, among such contractors, shall be decided by draw of lots in the presence of Chief Executive Officer, PSCDL and the lowest contractors those have quoted equal amount of their tenders. In case all the lowest contractors those have quoted same tendered amount, refuse to submit revised offers, then tenders are to be recalled after forfeiting 50% of EMD of each contractor. Contractor(s), whose earnest money is forfeited because of non-submission of revised offer, shall not be allowed to participate in the re-tendering process of the work.

5. The officer inviting tender or his duly authorized assistant, will open tenders in the presence of any intending contractors who may be present at the time, and will enter the amounts of the several tenders in a comparative statement in a suitable form. In the event of a tender being accepted, a receipt for the earnest money shall thereupon be given to the contractor who shall thereupon for the purpose of identification sign copies of the specifications and other documents mentioned in Rule-1. In the event of a tender being rejected, the earnest money shall thereupon be returned to the contractor remitting the same, without any interest.

6. The officer inviting tenders shall have the right of rejecting all or any of the tenders and will not be bound to accept the lowest or any other tender.

7. The receipt of an accountant or clerk for any money paid by the contractor will not be considered as any acknowledgement or payment to the officer inviting tender and the contractor shall be responsible for seeing that he procures a receipt signed by the officer inviting tender or a duly authorized Cashier.

8. The memorandum of work tendered for and the schedule of materials to be supplied by the Puducherry Smart City Development Limited and their issue-rates, shall be filled and completed in the office of the officer inviting tender before the tender form is issued. If a form is issued to an intending tenderer without having been so filled in and incomplete, he shall request the officer to have this done before he completes and delivers his tender.

9. The tenderers shall sign a declaration under the official Secret Act 1923, for maintaining secrecy of the tender documents drawings or other records connected with the work given to them. The unsuccessful tenderers shall return all the drawings given to them.

9A. Use of correcting fluid, anywhere in tender document is not permitted. Such tender is liable for rejection.

APPLICABLE FOR ITEM RATE TENDER ONLY

10. In the case of Item Rate Tenders, only rates quoted shall be considered. Any tender containing percentage below/above the rates quoted is liable to be rejected. Rates quoted by the contractor in item rate tender in figures and words shall be accurately filled in so that there is no discrepancy in the rates written in figures and words. However, if a discrepancy is found, the rates which correspond with the amount worked out by the contractor shall unless otherwise proved be taken as correct. If the amount of an item is not worked out by the contractor or it does not correspond with the rates written either in figures or in words, then the rates quoted by the contractor in words shall be taken as correct. Where the rates quoted by the contractor in figures and in words tally, but the amount is not worked out correctly, the rates quoted by the contractor will unless otherwise proved be taken as correct and not the amount. In event no rate has been quoted for any item(s), leaving space both in figure(s), word(s), and amount blank, it will be presumed that the contractor has included the cost of this/these item(s) in other items and rate for such item(s) will be considered as zero and work will be required to be executed accordingly.

APPLICABLE FOR PERCENTAGE RATE TENDER ONLY

10 A. In case of Percentage Rate Tenders only percentage quoted shall be considered. Any tender containing item rates is liable to be rejected. Percentage quoted by the contractor in percentage rate tender shall be accurately filled in figures and words, so that there is no discrepancy.

11. In the case of any tender where unit rate of any item/items appear unrealistic, such tender will be considered as unbalanced and in case the tenderer is unable to provide satisfactory explanation, such a tender is liable to be disqualified and rejected.

APPLICABLE FOR ITEM RATE TENDER ONLY

12. All rates shall be quoted on the tender form. The amount for each item should be worked out and requisite totals given. Special care should be taken to write the rates in figures as well as in words and the amount in figures only, in such a way that interpolation is not possible. The total amount should be written both in figures and in words. In case of figures, the word 'Rs.' should be written before the figure of rupees and word 'P' after the decimal figures, e.g. 'Rs. 2.15 P' and in case of words, the word, 'Rupees' should precede and the word 'Paise' should be written at the end. Unless the rate is in whole rupees and followed by the word 'only' it should invariably be upto two decimal places. While quoting the rate in schedule of quantities, the word 'only' should be written closely following the amount and it should not be written in the next line.

APPLICABLE FOR PERCENTAGE RATE TENDER ONLY

12 A. In Percentage Rate Tender, the tenderer shall quote percentage below/above (in figures as well as in words) at which he will be willing to execute the work. He shall also work out the total amount of his offer and the same should be written in figures as well as in words in such a way that no interpolation is possible. In case of figures, the word 'Rs.' should be written before the figure of rupees and word 'P' after the decimal figures, e.g. 'Rs. 2.15P and in case of words, the word 'Rupees' should precede and the word 'Paisa' should be written at the end.

13.(i) The contractor whose tender is accepted will be required to furnish performance guarantee of 5% (Five Percent) of the tender amount within the period specified in Schedule F. This guarantee shall be in the form of cash (in case guarantee amount is less than Rs. 10000/-) or Deposit at Call receipt of any scheduled bank/Banker's cheque of any scheduled bank/Demand Draft of any scheduled bank/ Pay order of any Scheduled Bank of any scheduled bank (in case guarantee amount is less than Rs. 1,00,000/-) or Government Securities or Fixed Deposit Receipts or Guarantee Bonds of any Scheduled Bank or the State Bank of India in accordance with the prescribed form. The earnest money deposited alongwith tender shall be returned after receiving the aforesaid performance guarantee.

(a) On evaluation of tender and if the tender is found that the overall amount quoted is below 15% and more than below 15.00%, then the contractor shall be asked to pay an additional performance guarantee amounting to 50% of the difference between the quoted amount and estimate cost put to tender. Failure to furnish the additional performance guarantee over and above the normal performance guarantee of 5% within the specified period from the date of receipt of acceptance letter, shall entitle cancellation of award and forfeiture of EMD furnished.

(b) This period can be further extended at the written request of the contractor by the Engineer-in-charge for a maximum period ranging from 1 to 15 days with late fee @ 0.1% per day, of performance guarantee amount.

In case the contractor fails to deposit the said performance guarantee and additional performance guarantee, if any, within the period as indicated in Schedule 'F', including the extended period if any, the Earnest Money deposited by the contractor shall be forfeited automatically without any notice to the contractor.

(ii) The contractor whose tender is accepted will also be required to furnish by way of Security Deposit for the fulfillment of his contract, an amount equal to 2.5% of the tendered value of the work. The Security deposit will be collected by deductions from the running bills as well as final bill of the contractor at the rates mentioned above. The Security amount will also be accepted in cash or in the shape of Government Securities. Fixed Deposit Receipt of a Scheduled Bank or State Bank of India will also be accepted for this purpose provided confirmatory advice is enclosed.

14. On acceptance of the tender, the name of the accredited representative(s) of the contractor who would be responsible for taking instructions from the Engineer-in-Charge shall be communicated in writing to the Engineer-in-Charge.

15. This work is covered under Puducherry Goods and Service Tax Act, 2017 and Central Goods and Service Tax Act 2017, hence the contractors are requested to quote the rates including the effect of GST. Additional/Separate claim for GST will not be entertained on any account after the award of work. The payment is also liable for TDS as per provision of GST Act and Rules.

16. The contractor shall give a list of both gazetted and non-gazetted Puducherry Smart City Development Limited employees related to him.

17. The tender for the work shall not be witnessed by a contractor or contractors who himself/ themselves has/have tendered or who may and has/have tendered for the same work. Failure to observe this condition would render, tenders of the contractors tendering, as well as witnessing the tender, liable to summary rejection.

18. The contractor shall submit list of works which are in hand (progress) in the following form:-

Name of Work (1)	Name & particulars of divn. Where work is being executed (2)	Value of work (3)	Position of works in progress (4)	Remarks (5)

19. The contractor shall comply with the provisions of the Apprentices Act 1961, and the rules and orders issued thereunder from time to time. If he fails to do so, his failure will be a breach of the contract and the Chief Executive Officer, PSCDL may in his discretion, without prejudice to any other right or remedy available in law, cancel the contract. The contractor shall also be liable for any pecuniary liability arising on account of any violation by him of the provisions of the said Act.

20. The contractor/firm must obtain necessary prior permit from **Pondicherry Ground Water Authority**, for the water requirement of the proposed construction/road works which will be met out either from tube well or transportation through tanker lorries before commencement of the construction work.

21. Inviting guidelines prescribed by the Central Vigilance Commission “**No post tender negotiation**” shall be conducted with the tenderers. The tenderers are expected to quote their rates with permissible limit of variation.

22. The contractor must study the plans appended with the tender and quote the rate accordingly.

For any clarification the contractors are free to contact the Engineer In-Charge, Puducherry Smart City Development Limited, Puducherry.

PROFORMA OF SCHEDULES

SCHEDULE "A"

Schedule of quantities (Refer page 50 to 53 of this NIT)

SCHEDULE "B"

Schedule of materials to be issued to the contractor

S.No.	Description of item	Quantity	Rates in figures & words at which the material will be charged to the contractor	Place of issue
1	2	3	4	5
Contractor's own arrangement				

SCHEDULE "C"

Tools and plants to be hired to the contractor

SI.No.	Description	Hire charges per day	Place of issue
1	2	3	4
-NIL-			

SCHEDULE "D"

Extra schedule for specific requirement/document for the work. if any - **NIL**

SCHEDULE “E”

Reference to General Conditions of contract: General Conditions of Contract for Puducherry Smart City Development Limited, Puducherry.

Name of Work:	“Providing & Fixing Decorative LED Lighting from Kargil War Memorial to Northern Reef and Duplex Statue to Pier (Old Port) of Beach Promenade in Puducherry”.
Estimated cost of work:	₹ 11,85,900/-
(i) Earnest money	₹ 23,718/- (to be returned after receiving performance guarantee)
(ii) (a) Performance Guarantee	5% of tendered value.
(b) Additional Performance Guarantee (in case of tender which is 15.00% below and more than 15.00% below)	50% of difference in cost between the quoted amount and estimate cost put to tender
(iii) Security Deposit	2.5% of tendered value (or) 2.5% of tendered value plus 50% of PG for contracts involving maintenance of the building, roads, bridges and services/other works after construction of same building, roads, bridges and services /other works.

SCHEDULE "F"

GENERAL RULES & DIRECTIONS

Officer inviting tender	CHIEF EXECUTIVE OFFICER, PUDUCHERRY SMART CITY DEVELOPMENT LIMITED, PUDUCHERRY
Definitions:	
2(v) Engineer-in-Charge	General Manager, PSCDL
2(viii) Accepting Authority	The Chief Executive Officer, Puducherry Smart City Development Limited, Puducherry.
2(x) Percentage on cost of materials and Labour to cover all overheads and profits.	15%
2(xi) Standard Schedule of Rates	Puducherry Schedule of Rates (Electrical) for the year 2018-19, G.O Ms.52 dt.25.09.2020 & Market rate applicable to Puducherry region inclusive of GST as applicable
2(xii) Department	Puducherry Smart City Development Limited
9(ii) Standard Puducherry Smart City Development Limited contract Form	GCC 2014 (PUDUCHERRY SMART CITY DEVELOPMENT LIMITED Form 7/8) as Available in the website https://pondicherrysmartcity.in

Clause 1	(i)	Time allowed for submission of Performance Guarantee from the date of issue of letter of acceptance	10 days
	(ii)	Maximum allowable extension with late fee @ 0.1% per day of performance Guarantee amount beyond the period provided in (i) above	10 days (1 to 15 days to be filled by NIT approving authority)
Clause 2		Authority for fixing compensation under clause 2	The Chief Executive Officer, PSCDL
Clause 2A		Incentive for early completion of work	Deleted
Clause 5		Number of days from the date of issue of letter of acceptance for reckoning date of start	7 days

Mile stone(s) as per table given below:

Sl. No.	Description of Milestone(Physical)	Time allowed in days (from date of start)	Amount to be with-held in case of non achievement of milestone
1.			
2.			
3.			
4.			

Time allowed for execution of work. **2 Months** (including monsoon period)

(Or)

Sl. No.	Financial Progress	Time allowed in days (from date of start)	Amount to be with-held in case of non achievement of milestone
1.	1/8 th (of the whole work)	1/4 th (of the whole work)	In the event of not achieving the necessary progress as assessed from the running payments, 1% of the tendered value of work will be withheld automatically for failure of each milestone without any notice to the contractor.
2.	3/8 th (of the whole work)	1/2 (of the whole work)	
3.	3/4 th (of the whole work)	3/4 th (of the whole work)	
4.	Full	Full	

Authority to decide:

- (i) **Extension of time** : Chief Executive Officer, PSCDL
- (ii) **Rescheduling of mile stone:** Chief Executive Officer, PSCDL
- (iii) **Shifting of date of start in case of delay in handing over of site :**
Chief Executive Officer, PSCDL

Clause 6 (or) 6A	Measurement of work done (or) Computerised Measurement Book	6
Clause 7	Gross work to be done together with net payment /adjustment of advances for material collected, if any since the last such payment for being eligible to interim payment	Rs. 5.93 lakhs

Clause 10A

List of testing equipment to be provided by the contractor at site lab: NIL

Clause 10B(ii) : Mobilisation Advance ~~Applicable~~ / Not applicable

Clause 10C : ~~Applicable~~ / Not applicable

Component of labour
expressed as percent of value of work **25 %**

Clause 10CA : ~~Applicable~~ / Not applicable

S.N.	Materials covered Under this clause	Nearest Materials (other than cement, reinforcement bars, the structural steel and POL) for which All India Wholesale Price Index to be followed	Base Price and its corresponding period of all the materials covered under Clause10 CA
1.	Cement	--nil--	As per PSR 2018-19 (Revised) applicable to Puducherry Region
2.	Steel	--nil--	

- » Includes Cement component used in RMC brought at site from outside approved RMC plants,if any.
- » Base price and its corresponding period of all the materials covered under Clause10 CA is to be mentioned **at the time of approval of NIT**. In case of recall of tenders, the base price may be modified by adopting latest base price and its corresponding period.

Clause 12.2 & 12.3	Deviation Limit beyond which clauses 12.2 & 12.3 shall apply for building work (Super Structure)	30%
12.5 (i)	Deviation Limit beyond which clauses 12.2 & 12.3 shall apply for foundation work (except items mentioned in earth work subhead in PSR and related items)	100%
(ii)	Deviation Limit for items mentioned in earth work subhead of PSR and related items	100%
Clause 16	Competent Authority for deciding reduced rates	Chief Executive Officer, PSCDL

Clause 18

**List of mandatory machinery, tools & plants to be deployed by the contractor at site:
As required.**

-- NIL --

Clause 25

Constitution of Dispute Redressal Committee (DRC)

- 1. Chairman** : Chief Executive Officer, PSCDL
- 2. Member** : Joint Chief Executive Officer, PSCDL
- 3. Member** : Chief Technical Officer, PSCDL
- 4. Member** : General Manager (Project)
- 5. Member** : General Manager (Planning & Procurement)

Clause 36(i)

Requirement of Technical Representative(s) and recovery Rate

Sl. No	Minimum Qualification of Technical Representative	Discipline	Designation (Principal Technical/ Technical representative)	Minimum Experience	Number	Rate at which recovery shall be made from the contractor in the event of not fulfilling provision of clause 36(i)	
						Figures	Words
1.	Graduate Engineer (or) Diploma Engineer	Electrical	Project/Planning/ Billing Engineer	2 Years (or) 5 Years	1	Rs.15,000/- PM	Rupees Fifteen Thousand per month

Assistant Engineers retired from Government services that are holding Diploma will be treated at par with Graduate Engineers.

Diploma holder with minimum 10 year relevant experience with a reputed construction company can be treated at par with Graduate Engineers for the purpose of such deployment subject to the condition that such diploma holders should not exceed 50% of requirement of degree engineers.

Clause 42 (i) (a)	Schedule / statement for determining theoretical quantity of cement & bitumen on the basis of Puducherry	Puducherry Schedule of Rates 2018-19 (Revised)
(ii)	Variations permissible on theoretical quantities	
(a)	Cement: For works with estimated cost put to tender not more than Rs.5lakh	3% plus/minus
	For works with estimated cost put to tender more than Rs.5 lakh	2% plus/minus
(b)	Bitumen: All works	2.5% plus & only & NIL on minus side

(c)	Steel Reinforcement and structural steel; sections for each diameter, section and category	2% plus/minus
(d)	All other materials	NIL

RECOVERY RATES FOR QUANTITIES BEYOND PERMISSIBLE VARIATION

Sl. No.	Description of item	Rates in figures and words at which recovery shall be made from the contractor	
		Excess beyond permissible variation	Less use beyond permissible variation
1.	-NIL-	-NIL-	-NIL-

GENERAL CONDITIONS

- (1) The work shall in general be carried out in accordance with CPWD specifications for works 2009 with correction slips and issued from time to time. Revised CPWD Specification 2009 for cement mortar, cement concrete & RCC.
- (2) However if the said specifications differ from those given in the description of any particular item in the schedule of quantities and specifications stipulated herein, the latter shall prevail.
- (3) If the detailed description of any particular item in the schedule of quantities and specifications finally accepted by the Puducherry Smart City Development Limited differs from the particular specifications given hereunder, the former shall prevail to the extent applicable.
- (4) If the particular specification given hereunder differs from I.S. code provisions, in any respect, the former shall prevail.
- (5) Wherever any reference to any Indian standard specification occurs in the documents relating to this contract the same should be inclusive of all amendments issued thereto or revision thereof if any, upto the date of receipt of tenders.
- (6) Conditions involving any financial implications other than those covered in the schedule of quantities will not be entertained and such tenders are also liable to be rejected.
- (7) When working near existing structures, care shall be taken to avoid any damage to such structures, any such damage caused intentionally or unintentionally shall be restored to original and or acceptable condition and to the satisfaction of the Engineer-in-charge.
- (8) The contractor shall given to the Municipality, Police and other authorities all notices etc., that may be required to be given as per law and obtain all requisite licenses for temporary obstructions, enclosures and pay all fees, taxes and charges which may be leviable on account of the operations during the execution of the contract. No extra claim of the contractor will be entertained by the Puducherry Smart City Development Limited on this account.
- (9) Other agencies doing works related to this project may also simultaneously execute the works and the contractor shall co-ordinate and co-operate with them as found to be necessary at no extra cost.

(10) Any cement slurry or lime mortar or any combination thereof or water proofing material required for continuation from old work is demand to have been in built in the relevant items themselves and nothing extra shall be paid for the same.

(11) The rate for all items of the work shall be considered as inclusive of pumping out or bailing out water if required for which no extra payment will be made. This will include water encountered from any source as rains, flood, and subsoil water table being high due to any other cause whatsoever.

~~(12) The Contractor shall be required to establish complete field testing laboratory and arrange all the relevant codes and Standards. The list of such testing equipments. Codes and standards shall be specified in the tender documents. The contractor shall also arrange for more equipments, Codes and Standards. If they are needed during the execution of the work. The contractor shall also provide the minimum staff, as specified, for quality assurance. He shall also provide for a temporary shed, of the specified size and specifications at the allotted space at site for housing the testing laboratory.~~

CONDITIONS FOR ISSUE OF MATERIALS

The materials shall be issued to the contractor at the place of delivery as mentioned in schedule 'B'. If these are delivered at any other site, the difference due to cartage will be adjusted accordingly. The contractor shall have to cart at his cost the materials to the site of work as soon as these are issued. The materials shall be issued between the working hours and as per rules prevails in the stockyard of the materials as framed from time to time.

The contractor shall bear all incidental charges for cartage, storage and safe custody of materials. No reimbursement of the expenses will be made by the Puducherry Smart City Development Limited.

The contractor shall construct suitable godown at the site of work for storing the materials safe against damage of sun, rain, dampness, fire, theft etc. he shall also employ necessary watch and ward establishment for the purpose.

~~Cement bags shall be stored in separate godown with pucca floor weatherproof roofs and walls. Each godown shall be provided with a single door with two locks. The keys of one lock shall remain with the Puducherry Smart City Development Limited Engineer-in-charge of the work and that of the other lock with authorized agent of the contractor at the site of work so that the cement is removed from the godown accordingly to the daily requirements with the knowledge of both the parties.~~

~~The cement shall be stacked on proper floors consisting of two layers of dry bricks laid on well-consolidated earth at a level of at least 0.3 meters above ground level. These stocks shall be in row of 2 and 10 high with a minimum of 0.6 meter clear space around. The bags would be placed horizontally continuous in each line as shown in the sketch of C.P.W.D. specification 2009.~~

~~The day today receipts and issue accounts of cement shall be maintained buy the Engineer-in-charge and signed daily by the contractor or his authorized agent.~~

MATERIALS OBTAINED FROM DISMANTLEMENT

- I. The contractors, in course of their work, should understand that all materials (e.g. stone and the other materials) obtained in the work of dismantling, excavation etc. will be considered Puducherry Smart City Development Limited property and issued to the contractor (if they require the same for their own use) at rates approved by Puducherry Smart City Development Limited. If these materials are not required by them, they will dispose of to the best advantage of Puducherry Smart City Development Limited.

DELAY IN OBTAINING MATERIALS BY THE PUDUCHERRY SMART CITY DEVELOPMENT LIMITED

II. Owing to difficulty in obtaining certain materials in the open market, the Puducherry Smart City Development Limited have undertaken to supply materials specified in schedule 'B' of the tender forms at rates stated therein. There may be delay in obtaining the materials by the Puducherry Smart City Development Limited and the contractor is, therefore required to keep himself in touch with the day to day position regarding the supply of materials from the Engineer-in-charge and to so adjust the progress of their work that their labour may not remain idle nor may there be any other claim due to so arising from delay in obtaining the materials. It should be clearly understood that no claim whatsoever shall be entertained by the Puducherry Smart City Development Limited on account of delay in supplying materials.

III. M.S. or deformed bars shall be issued in lengths as available in stores. M.S. or deformed bars shall be issued in straights or in coils as available and nothing extra shall be payable for straightening the bars. The bars issued in available lengths shall be cut to the required lengths and nothing extra shall be payable for the same.

IV. The contractor shall have to deposit the approved paints of required color and shade as per actual requirements of the work to be done with the Engineer-in-charge at his PSCDL at the site of work.

The contractor shall be responsible for the water proofness of the roof for one full monsoon season after the date of completion. He shall rectify the defect noticed after due intimation in writing is given by the Engineer-in-charge failing which, Engineer-in-charge shall get the defects repaired at the contractor's risk and cost.

WATER SUPPLY AND SANITARY WORK

V. The contractor shall engage licensed plumber for the work and get the materials tested by the Puducherry Smart City Development Limited authorities whenever required at their own cost. The work shall be carried out according to the specification and the contractor shall produce necessary certificate from the appropriate authorities after completion of work.

VI. The contractor shall have to deposit water proofing compound as per the actual requirements for the water proofing job with the Engineer-in-charge at the site of work.

The water proofing compound will be issued to the contractor from time to time according to his requirements for the work in the same manner as the issue of the materials stipulated to be issued departmentally.

INCONVENIENCE TO PUBLIC

VII. The contractor shall not deposit materials on any site, which will seriously inconvenience the public. The Engineer-in-charge may require the contractor to remove any materials, which are considered by him to be a danger or inconvenience to the public or cause them to be removed at the contractor's cost.

VIII. Any damage to work resulting from rains or from any other cause until the work is taken over by the Puducherry Smart City Development Limited after completion will be made good by the contractor at his own cost.

IX. The contractor shall deposit royalty and obtain necessary permit for supply of sand, HBG metal, red earth, etc. from local authorities.

X. The contractor shall get himself acquainted with the nature and extent of the work and satisfy himself about the availability of quarry and of kiln for collection and conveyance of materials required for the construction. The contractor's quoted rate should take into account all these factors and will not be allowed for extra lead for collection and conveyance of materials for any reason whatsoever.

XI. The contractor will be permitted to set up labour camp only before a week from the commencement of work and not exceeding fifteen days after the completion of the work.

XII. The contractor shall conform to the provision of any government acts which relate to works and to the regulations and bye-laws of any local authorities. The contractors shall give all notices required by the said acts or laws etc., pay all fees payable to such authorities and allow for these contingencies in his tendered rates including fees for encroachments, costs of restoration etc., and all other fees payable to the local authorities.

XIII. Where surplus earth of a suitable quality exists at the site of work, the contractor shall be allowed to use same free of cost making mud mortar for masonry and for laying mud terracing over the roof. The Engineer-in-charge shall be the final authority to decide whether the earth obtained from excavation is surplus or not.

The surplus earth excavated which is beyond the requirement of Puducherry Smart City Development Limited, may be allowed by the Engineer-in-charge to be disposed of by the contractor on his own or to sell the surplus earth to private parties at his discretion, but nothing extra will be paid for carriage or disposal of the surplus earth, if the same is not required for Puducherry Smart City Development Limited works.

The debris should be removed from the site on day to day basis without affecting the public in general.

The mixing of concrete should be done at a separate site avoiding stacking of material at road side.

Wherever fine sand has been mentioned in the schedule of quantities, it should be conforming to the grading Zone-IV or Zone-V as mentioned in the C.P.W.D. specifications.

XIV. Concrete will be mixed with mixers either operated by hand or mechanical.

XV. The contractor shall not employ women and men below the age of 18 on the work of painting with products lead, in any form wherever men above the age of 18 are employed on the work of lead painting, the following principles must be observed for such use:

- a) White lead sulphate or lead, of products containing these pigments shall not be in painting operation except in the form of paste or of paint ready for use.
- b) Measure shall be taken in order to prevent danger arising from application of paint in the form of spray.
- c) Measure shall be taken wherever practicable against danger arising from dust caused by dry rubbing down and scraping.

- d) Adequate facilities shall be provided to enable working painters to wash during and on cessation of work.
- e) Overalls shall be worn by working painters during whole of the working period.
- f) Suitable arrangements shall be made to prevent clothing put off during working hours being soiled by painting materials.
- g) Cases of lead poisoning and suspected lead poisoning shall be subsequently verified by a medical team appointed by the competent authority.
- h) The Puducherry Smart City Development Limited may require when necessary medical examination of workers.
- i) Instructions with regard to the special hygienic precautions to be taken in the painting trade shall be distributed to working painter.
- j) The standard section weights referred to as standard table of 5.4 in the C.P.W.D specification 2009 be considered for conversion of length of various size of steel bars into weights are as under:-

Nominal size mm	Cross sectional area Sq.mm.	Mass per metre run Kg.
6	28.3	0.222
8	50.3	0.395
10	78.6	0.617
12	113.1	0.888
16	201.2	1.58
20	314.3	2.47
25	491.1	3.85
28	615.8	4.83
32	804.6	6.31
36	1018.3	7.99
40	1257.2	9.86

Issue of steel diameter above 10mm will be regulated on sectional weights basis, weight being calculated with the help of the above tables. However, for bars TMT steel up to and including 10mm the following procedure shall be adopted. The average sectional weights for each diameter shall be arrived at from samples from each lot of steel received at site. The actual weight of steel issued shall be modified to take into account the variations between the actual and the standard co-efficients given above and the contractor's account will be debited by the cost of this modified quantity only. The discretion of the Engineer-in-charge shall be final for the procedure to be followed for determining the average sectional weight of each lot. Quantity of each diameter of steel received at site of work each day will constitute one single lot for this purpose.

SPECIAL CONDITIONS APPLICABLE FOR ROAD WORKS/BRIDGE WORKS

(1) Construction Equipment:

- 1.1 The methodology and equipment to be used on the project shall be furnished by the Contractor to the Engineer well in advance of commencement of work and approval of the Engineer obtained prior to its adoption and use.
- 1.2 The Contractor shall give a trial run of the equipment for establishing its capability to achieve the laid down specification and tolerance to the satisfaction of the Engineer before commencement of work, if so desired by the Engineer.
- 1.3 All equipment provided shall be proven efficiency and shall be operated and maintained at all times in a manner acceptable to the Engineer.
- 1.4 No equipment or personnel will be removed from site without permission of the Engineer.

(2) Work Program and Methodology of Construction:

The Contractor shall furnish his program of construction for execution of the work within the stipulated time schedule together with methodology of construction each item of work and obtain the approval of the engineer prior to actual commencement of work.

(3) Revised Programme of Work in case of Slippage:

In case of slippage from the approved work programme at any stage, the Contractor shall furnish revised programme to make up the slippage within the stipulated time schedule and obtain the approval of the Engineer to the revised programme.

(4) Action in case of Disproportionate Progress:

In case of extremely poor progress of the work or any item at any stage of work which in the opinion of the Engineer cannot be made good by the Contractor considering his available resources, the Engineer will get it accelerated to make up the lost time through any other agency and recover the additional cost incurred, if any, in getting the work done from the Contractor after informing him in writing about the action envisaged by him.

(5) Setting out:

Setting out the work as spelt out in clause 109 of Ministry's Specifications for Road and Bridge Works 5th Revision will be carried out by the Contractor.

(6) Public Utilities:

Action respect of public utilities will be taken by the contractor as envisaged in Clause 110 of Ministry's Specifications for Road and Bridge Works 5th Revision.

(7) Arrangement for traffic during construction :

Action for arrangement for traffic during construction will be taken by the contractor as envisaged in the contract documents and spelt out in clause 112 of Ministry's Specifications for Road and Bridge Works 5th Revision.

(8) Quality Control :

The onus of achieving quality of work will be on the contractor who will take action as stipulated in the Ministry's for Road and Bridge Works 5th Revision.

(9) Ministry's specification for Road and Bridge Works (5th Revision):

Ministry's specification for Road and Bridge Works 5th Revision will form part of the contract documents and the contractor will be legally bound to the various stipulations made therein unless and otherwise specifically relaxed or waived wholly or partly through a special clause in the contract document.

(10) Documentation:

The Contractor will prepare drawing (s) of the work as constructed and will supply original with three copies to the Engineer who will verify and certify these drawings. Final as constructed drawing(s) shall then be prepared by the Contractor and

supplied in triplicate along with a micro film of the same to the Engineer for record and reference purposes.

(11) The contractor shall make his own arrangement to provide the bitumen required for the work from approved public sector, refineries such as IOC, BP, HPL, etc. and produce the paid voucher to the Engineer-in-charge. The materials so procured shall be got tested before use.

(12) The use of rubber modified bitumen shall be as per the guide lines of "IRC SP 53-99"

(13) The Contractor shall use "Hydrostatic paver with sensor control" for this work.

(14) The Pile shall be terminated at a depth as per the direction of Engineer-in-charge.

(15) The defect liability period is Three Years where scope of work involves provision of structural layer i.e. strengthening where the total thickness of bituminous layer is 30 mm and above.

(16) The payment for the quantity of Road Work such as Bituminous Macadam (BM/DBM), Bituminous Concrete / Semi Dense Bituminous Concrete, Wearing Course shall be made based on the physical measurement of finished work in position in cum. or sqm. at a specified thickness or based on level measurements, whichever is less.

ADDITIONAL CONDITIONS

1. The rate for all items of works shall unless clearly specified otherwise include cost of all labour, materials and others inputs involved in the execution of item.
- 2(a) For the purpose of recording measurements and preparing running account bill the abbreviated nomenclature enclosed with the standard form shall be adopted .The abbreviated nomenclature shall be taken to cover all the materials and operations as per the complete nomenclature of the relevant items in the agreement and other relevant specifications.
(b) In case of extra and substituted items of work for which abbreviated nomenclature is not provided in the agreements, the full nomenclature of items shall be reproduced in the measurement books and bill forms for running account bills.
3. For all doors and windows whether factory made or otherwise, cleats and rubber buffers 30mm dia. shall be provided as directed by the Engineer-in-charge and the rate for the shutter item shall include the cost of providing such wooden cleats and buffers.
4. For those doors where hydraulic door closer is provided only wooden cleats need not be provided and no reduction in rate shall be made for the same.
5. The particle board shutter shall be provided, with teak wood lipping (beading) at the edge to which hinges are fixed, without any extra cost.
6. For works where items of aluminium doors, windows etc., are specified, the grade of anodic coating to be provided in accordance with table I of IS: 1868-1968 together with reference to IS: 5523-1969.
7. Where hydrated lime is available, this can be used on the works and the places where hydrated lime is not available, lime concrete will be prepared by the traditional method of slaking the lime preparing the lime putty etc.
8. (a) Tendered rates are inclusive of all taxes and levies payable under the respective status. However pursuant to the constitution (46th Amendment) Act 1982, if any further tax or levy is imposed by the statute after the date of receipt of tenders and the contractor thereupon necessarily and properly pays such taxes/levies, the contractors shall be reimbursed the amount so paid provided such payment, if, any, is not, in the opinion of the Engineer-in-Charge (whose decision shall be final and binding) attributable to delay in execution of work within the control of the contractor.
(b) The contractor shall keep necessary books of accounts and other documents for the purpose of this condition as may be necessary and shall allow inspection of the same by a duly authorized representative of Puducherry Smart City Development Limited and further shall furnish such other information/document as the Engineer-in-Charge may require.

(c) The contractor shall within a period of 30 days of imposition of any further tax or levy pursuant to the Constitution (46th Amendment) Act, 1982 give a written notice thereof to the Engineer-in-Charge pursuant to this condition, together with all necessary information relating therein.

9. Stipulated materials shall be issued for use at site of work for all the items where such materials are required. For factory made products like precast cement tiles, precast hollow concrete blocks, precast foam concrete blocks, precast RCC pipes etc., stipulated materials shall not be issued by the Puducherry Smart City Development Limited.

10. While execution of the work, the contractor shall organise his work in such a way that the normal functioning of the premises is not disturbed.

11. Any damage done to the existing structure while dismantling execution of the work shall be made good by the contractor at claim shall be made good by the contractor at his own cost and no extra claim shall be entertained on this account.

12. The contractor must see the site before participating the tender and his viability for executing the work.

13. The item of Anti-termite treatment shall be executed through a specialized firm.

14. Rates should be quoted for the items specified in the NIT and shall not be compared with the analysis of rates.

15. Rates for all items should be quoted based on the availability of construction materials in accordance to BIS/C.P.W.D specifications.

16. Rates should also be quoted inclusive of testing charges of all construction materials both at laboratory and in the field. No payment will be made for material testing.

17. The contractor should arrange for shifting of construction materials / concrete etc., near to the work site at his own cost. No extra rate shall be considered for shifting of materials etc.

18. For construction of Buildings /drains/canals/channels/bridges and culverts etc., rates should be quoted inclusive of de-watering and pumping out any type of water encountered during execution. No separate claim/ cost (like Extra/Substituted/Deviated items) will be admitted towards the dewatering etc. or any form of claim at any stage during the execution of work. No extra claim will be admitted for working under foul condition encountered during execution.

19. The Contractors themselves have to identify the place of disposal of un-serviceable materials like debris, waste mud, etc arises in the site. No extra lead and lift shall be considered for such disposal.

20. The Contractor must do their own arrangements at their own cost for signage/barricading etc. for the safety of Public during construction in the construction site of building/road/drain/canal/bridge/culverts etc. No separate claim will be admitted in this regard.

21. The contractor should not discontinue/suspend/slowdown the work on the grounds of non-payment of work bills, as the contractor in terms of Clause 7 of agreement is eligible for interest for the belated payment. If the contractor fails to continue the work in letter and spirit of agreement and other accepted terms and conditions, on the grounds of non-payment of work

bills, the contract will be terminated. In the event of non-payment of work bills, the contract as per Clause-I of the Conditions of Contract and accrued Security Deposit will be forfeited.

22. The contractor shall make his own arrangements to provide the steel required for the work from SAIL / IISCO / TISCON / VIZAG / JSW STEEL PLANT and produce the paid voucher to the Engineer-in-Charge. The materials so procured shall be got tested before use.

23. The contractor shall procure 43 grade OPC / PPC cement having ISI mark from reputed firms having annual turn over of not less than one million MT and stores it in the site godown as per the guidelines specified in the CPWD specification 2009 under double lock system. The paid voucher of the cement procured shall be produced to the Engineer-in-Charge. The cement procured shall be got tested before use.

24. The contractor shall make his own arrangements to provide the bitumen required for the work from approved public sector, refineries such as IOC, BP, HPL etc., and produce the paid voucher to the Engineer-in-Charge. The materials so procured shall be got tested before use.

25. Necessary test certificates should be produced from the approved laboratory for the quality of materials.

26. Defective materials will be rejected and the same have to be reparable by the contractor at his own cost.

27. Original purchase vouchers should be produced at the time of receipt of materials and at the time of verification by the Engineer-in-Charge. The name of contractor, name of work and agreement number should be clearly noted in the original vouchers.

28. The test specimens shall be provided at free of cost by the contractor.

29. The test for cement has to be conducted for every 1000 bags or part. The test for steel has to be conducted for every consignment of 20 tonne or part thereof for each size/dia.

30. Payment for the item of laying Semi Dense Bituminous Concrete shall be made after conducting the density / compaction measurement test and also the surface roughness measured with Bump Integrator, by the Highways Research Station, Chennai and ensuring that

(a). In respect of density /compaction, the test result conforms to the density prescribed in the mix design and,

(b). In respect of surface roughness measured with Bump Integrator the result shall conform to the values prescribed in Table – 3 of IRC – SP-16-2004.

ADDITIONAL CONDITIONS II

ADOPTION OF PSR ABBREVIATED NOMENCLATURE

The Puducherry Schedule of Rates Abbreviated Nomenclature for buildings and road works shall be adopted in recording of measurements and preparation of running account bills, etc., wherever applicable as per C.P.W.D. Works Manual 2014.

PARTICULAR SPECIFICATIONS

1. The work executed shall be measured as per metric dimensions given in the schedule of quantities. The FPS units wherever indicated in the drawings are for guidance only.
2. Unless otherwise specified, all the rates quoted by the contractor shall be for items of work at all levels and heights of the building.
3. The work shall be executed as per the C.P.W.D. specifications 2009 (with correction slips and subsequent publications). In case of discrepancies between the specifications of a particular item as indicated in the C.P.W.D. specifications mentioned above and as indicated in the nomenclature of the item the latter shall prevail.
4. All stone aggregate, sand etc., shall be obtained only from approved quarries. All the materials shall be got approved by the Engineer-in-Charge before they are actually procured and used at site.
5. The grading of sand to be used for mortars and concrete shall be determined at the site of work by the Engineer-in-Charge and sand conforming to these gradings only shall be used on the work.
6. Necessary washing, screening, etc., of metal and sand shall be done at site as per requirements of the Engineer-in-Charge.
7. Bricks shall have crushing strength of class designation.
8. The work of water supply and internal sanitary installations and drainage shall be carried out as per bye-laws of the local Municipal body.
9. All manufactured materials used in the work shall have ISI/BIS mark. In case of materials for which no manufacturer has been licensed to manufacture the materials with ISI marking, the materials shall conform to the provisions of C.P.W.D./MORTH/IRC/CPHEEO specifications or the ISI code (in the absence of C.P.W.D. specifications or other specification mentioned above for any particular material). In the case of all materials, tests shall be conducted to ensure that they conform to the specifications of codes mentioned above.
10. All materials, which are to be tested before use on the work should be procured at least 2 months before use on the work so that enough time is available for testing them before they are actually used.
11. The cost of samples and all other incidental charges such as packing, transportation to the laboratory etc., shall be borne by the contractor.
12. The architectural drawings Nos. based on which the work is to be executed are available with the Engineer-in-Charge and can be inspected by the prospective tenderers up to the date of submission of tenders at his office during working hours.

Use and testing of all the manufactured materials used in the work shall be regulated as per specifications 2009.

13. Before receiving final payment for the work, contractor shall give an undertaking to the effect that at his own cost he will rectify the defects in walls, roof like leakage, cracks etc. Which may come to light during the first monsoon after the completion of work and for this purpose part of the security deposit which may be deemed reasonable by the Engineer-in-Charge shall be retained till the first monsoon is over as security against the contractor's failure to act upon the undertaking. This undertaking and consequent retention of part of the security deposit shall not invalidate the contract.

The timber to be used on the work shall be of first class wood of species mentioned in the particular item. The timber shall be kiln seasoned as per B.I.S. 1141 – 1973 and shall be treated with non-leach able type preservative by vacuum pressure method as per B.I.S. 401 – 1982.

FACTORY MADE PANELLED SHUTTERS FOR DOORS

14. The shutters shall be fabricated generally as per I.S. 1003 (Part I) – 1997 and as per Architect's drawings. The timber to be used shall be of first class wood of species mentioned in the particular item which shall be kiln seasoned and preservative treated. The panels shall be as specified in the item number. Samples of shutters shall be got tested as per I. S. 1003 (Part I) – 1997. The rate quoted for the item shall include the element of cost of shutter to be sent for testing and no claim on this account shall be entertained at a later date.

15. Pressed clay tiles to be used on the work shall conform to I. S. 2690 (Part I) – 1975. However, the water absorption of the tiles when tested by the method described in the Appendix 'A' of the said I. S. 2690 (Part I) 1975 shall not exceed 18% (Eighteen percent.).

16. Shahabad stone slabs, marble slabs etc. on treads and risers of steps and shelves shall be in single pieces.

P.V.C. PIPES INTERNAL WORK AND EXTERNAL WORK

17. The specification in respect of laying and jointing rigid P.V.C. threaded pipes both internal and external shall be as per C.P.W.D. specifications. The rigid P.V.C. threaded pipes shall conform to relevant ASTM standard and shall be ORIPLAST or equivalent.

18. Wherever RCC walls, fins and facial are monolithic the portion of RCC are to be measured as per the sketch attached in Page No.

19. The top surface of the RCC roof slab shall be screeded to be uniform when the concrete is green, so as to have a proper bond with the roof treatment. Nothing extra shall be paid on this account.

20. For aluminium doors, fixed glazing, fixed windows, sliding windows, louvered type ventilators and partitions etc. all aluminium sections shall be to the required size, thickness and weight as shown in the relevant Architect's Drawings.

21. The weight of stays given in C.P.W.D. specifications 2009 shall be for cast brass stays only.

The weight of the mild steel and anodized aluminium stays shall be as follows: -

Casement stays (Straight peg type)	Mild steel with tolerance of plus or minus %	Anodized aluminium with tolerances of plus or minus %
(a) 300 mm long	0.13 Kg/each	0.06 Kg/each
(b) 250 mm long	0.10 Kg/each	0.05 Kg/each
(c) 200 mm long	- The casement window fasteners	0.04 Kg/each 0.155 kg/each

Form of Earnest Money Deposit

Bank Guarantee Bond

WHEREAS, contractor..... (Name of contractor) (hereinafter called "the contractor") has submitted his tender dated (date) for the construction of (name of work) (hereinafter called "the Tender")

KNOW ALL PEOPLE by these presents that we (name of bank) having our registered office at (herein after called the bank) are bound unto (Chief Executive Officer, PSCDL) in the sum of Rs. (Rs. in words) for which payment well and truly to be made to the said Chief Executive Officer, PSCDL the Bank binds itself, his successors and assigns by these presents.

SEALED with the Common Seal of the said Bank this day of 20... . THE CONDITIONS of this obligation are:

(1) If after tender opening the Contractor withdraws, his tender during the period of validity of tender (including extended validity of tender) specified in the Form of Tender;

(2) If the contractor having been notified of the acceptance of his tender by the Chief Executive Officer, PSCDL:

(a) fails or refuses to execute the Form of Agreement in accordance with the Instructions to contractor, if required;

OR

(b) fails or refuses to furnish the Performance Guarantee, in accordance with the provisions of tender document and Instructions to contractor,

We undertake to pay to the Chief Executive Officer, PSCDL either up to the above amount or part thereof upon receipt of his first written demand, without the Chief Executive Officer, PSCDL having to substantiate his demand, provided that in his demand the Chief Executive Officer, PSCDL will note that the amount claimed by his is due to him owing to the occurrence of one or any of the above conditions, specifying the occurred condition or conditions.

This Guarantee will remain in force up to and including the date* after the deadline for submission of tender as such deadline is stated in the Instructions to contractor or as it may be extended by the Chief Executive Officer, PSCDL notice of which extension(s) to the Bank is hereby waived. Any demand in respect of this Guarantee should reach the Bank not later than the above date.

DATE

WITNESS

(SIGNATURE, NAME AND ADDRESS)

SIGNATURE OF THE BANK

SEAL

*Date to be worked out on the basis of validity period of 6 months from last date of receipt of tender.

Form of Performance Security (Guarantee)

Bank Guarantee Bond

In consideration of the Puducherry Smart City Development Limited (~~hereinafter called "The Government"~~) having offered to accept the terms and conditions of the proposed agreement between.....and (hereinafter called "the said Contractor(s)") for the work..... (hereinafter called "the said agreement") having agreed to production of an irrevocable Bank Guarantee for Rs. (Rupees.....

..... only) as a security/guarantee from the contractor(s) for compliance of his obligations in accordance with the terms and conditions in the said agreement.

1. We, (hereinafter referred to as "the Bank") hereby undertake to pay to the Puducherry Smart City Development Limited an amount not exceeding Rs. (Rupees..... Only) on demand by the Puducherry Smart City Development Limited.

2. We,(indicate the name of the Bank) do hereby undertake to pay the amounts due and payable under this guarantee without any demure, merely on a demand from the Puducherry Smart City Development Limited stating that the amount claimed as required to meet the recoveries due or likely to be due from the said contractor(s). Any such demand made on the bank shall be conclusive as regards the amount due and payable by the bank under this Guarantee. However, our liability under this guarantee shall be restricted to an amount not exceeding Rs.....

(Rupeesonly)

3. We, the said bank further undertake to pay the Puducherry Smart City Development Limited any money so demanded notwithstanding any dispute or disputes raised by the contractor(s) in any suit or proceeding pending before any court or Tribunal relating thereto, our liability under this present being absolute and unequivocal. The payment so made by us under this bond shall be a valid discharge of our liability for payment thereunder and the Contractor(s) shall have no claim against us for making such payment.

4. We, (indicate the name of the Bank) further agree that the guarantee herein contained shall remain in full force and effect during the period that would be taken for the performance of the said agreement and that it shall continue to be enforceable till all the dues of the Puducherry Smart City Development Limited under or by virtue of the said agreement have been fully paid and its claims satisfied or discharged or till Chief Executive Officer on behalf of the Puducherry Smart City Development Limited certified that the terms and conditions of the said agreement have been fully and properly carried out by the said Contractor(s) and accordingly discharges this guarantee.

5. We, (indicate the name of the Bank) further agree with the Puducherry Smart City Development Limited that the Puducherry Smart City Development Limited shall have the fullest liberty without our consent and without affecting in any manner our obligation hereunder to vary any of the terms and conditions of the said agreement or to extend time of performance by the said Contractor(s) from time to time or to postpone for any time or from time to time any of the powers exercisable by the Puducherry Smart City Development Limited against the said contractor(s) and to forbear or enforce any of the terms and conditions relating to the said agreement and we shall not be relieved from our liability by reason of any such variation, or extension being granted to the said Contractor(s) or for any forbearance, act of omission on the part of the Puducherry Smart City Development Limited or any indulgence by the Puducherry Smart City Development Limited to the said Contractor(s) or by any such matter or thing whatsoever which under the law relating to sureties would, but for this provision, have effect of so relieving us.

6. This guarantee will not be discharged due to the change in the constitution of the Bank or the Contractor(s).

7. We, (indicate the name of the Bank) lastly undertake not to revoke this guarantee except with the previous consent of the Puducherry Smart City Development Limited in writing.

8. This guarantee shall be valid up tounless extended on demand by the Puducherry Smart City Development Limited.

Notwithstanding anything mentioned above, our liability against this guarantee is restricted to Rs. (Rupees) and unless a claim in writing is lodged with us within six months of the date of expiry or the extended date of expiry of this guarantee all our liabilities under this guarantee shall stand discharged.

Dated theday offor.....(indicate the name of the Bank)

Declaration to be submitted by the Contractor:

I have carefully read all the pages, conditions of this Tender Document and inspected the site before quoting the rates for this tender and accordingly quoted the rates to suit the site condition.

CONTRACTOR

SCHEDULE – A

NAME OF WORK: Providing & Fixing Decorative LED Lighting from Kargil War Memorial to Northern Reef and Duplex Statue to Pier (Old Port) of Beach Promenade in Puducherry.

Sl. No.	Code no.	Description	Units	Qty	Unit Price		Amount
					In figure	In words	
1	NPSR 1	Supply of Decorative classic LED Post Top lantern with system wattage of 50W, BIS certified with a luminaire body made of cast and spun aluminium, permanently sealed optical block (IP66) with heat sink and PMMA protector (IK07) fitted with a Vent Plug pressure equalisation unit, fixed onto a hinged spun aluminium frame, control gear compartment accessed by loosening one screw for tool free opening and closing. Highly efficient temperature resistant lenses for symmetric or asymmetric light distribution with several optical options providing excellent photometry to optimally cater to different applications. Suitable for galvanised painted mounting bracket for Post Top version. Overall system efficiency of 115lm/W at correlated colour temperature (CCT) of 3000 K - 4000K , colour rendering index (CRI) >70 and L70 rated lifetime of 50,000 hours. Electrical Class I, rated voltage 240Vac, Power Factor ≥ 0.95, with BIS certified potted driver having internal surge protection of 4/4 kV and an additional surge protection device (SPD) of 10/10kV (in both Common & Differential Modes). Keselec VALE / Philips / Bajaj - LED Post Top	Nos.	8			

2	NPSR 2	Supply of Decorative Column 5.0 metre height above the ground level made out of GI, tubular pole 'T' washed and primered. (ASTM A123, with minimum average GI coating of 65µm.), having two sections, bottom section of minimum 1000mm (L) x 140mm dia and the top section with minimum of 4000mm (L) x 76mm dia, in built junction looping box at bottom section with 32 A heavy duty 4 way connector for loop in & loop out. The Embellishments are cast in iron and fitted to the column by grubs screw fitting. Design comply EN40 standard and basic wind speed 169kmph. The embellishments shall be sealed to the column. The Pole Base plate should be with 250x250x12 mm. The column shall also be provided with flush door at the bottom with proper strengthening to the cut-out of the door opening. The column should be given with two coats of epoxy primer and above that it should be given with polyurethane UV resistant coating (painted with avg. DFT of 70µm). The complete system should be hot dipped Galvanised & Marine grade treated. Keselec Blenheim / Philips / Bajaj - Pole 5.0M GI PU painted	Nos.	8			
3	NPSR 3	Supply of Decorative classic LED Post Suspended with system wattage of 50W, BIS certified with a luminaire body made of cast and spun aluminium, permanently sealed optical block (IP66) with heat sink and PMMA protector (IK07) fitted with a Vent Plug pressure equalisation unit, fixed onto a hinged spun aluminium frame, control gear compartment accessed by loosening one screw for tool free opening and closing. Highly efficient temperature resistant lenses for symmetric or asymmetric light distribution with several optical options providing excellent photometry to optimally cater to different applications. Suitable for galvanised painted mounting bracket for Suspended Version. Overall system efficiency of 115lm/W at correlated colour temperature (CCT) of 3000K - 4000K , colour rendering index (CRI) >70 and L70 rated lifetime of 50,000 hours. Electrical Class I, rated voltage 240Vac, Power Factor ≥ 0.95, with BIS certified potted driver having internal surge protection of 4/4 kV and an additional surge protection device (SPD) of 10/10kV (in both Common & Differential Modes). Keselec VALE / Philips / Bajaj - 50W LED Suspended	Nos	15			

4	5.2	Earthing with G.I. earth pipe 4.5 meter long, 40 mm dia including accessories , and providing masonry enclosure with cover plate having locking arrangement and watering pipe etc. with charcoal / coke and salt as required	set	3			
5	5.7	Supplying and laying 6 SWG G.I. wire at 0.50 meter below ground level for conductor earth electrode, including connection / termination with GI thimble etc. as required	Mtrs	160			
6	14.4	Excavation for cable trenches in soft soil , depth upto 1.2 m including dressing of sides lift upto 1.5m , including getting out the excavated soil , refilling with sand and good soil after laying of cable / pipe etc. in layers of 20cm , ramming, watering and disposal of surplus excavated soil as directed , within a lead of 50 meters	Cum	40			
7	14.5	Deduct for not consolidation by ramming and watering while re-filling with sand and or good soil in cable / pipe laying	Cum	40			
8	14.7	Providing and laying in position cement concrete 1:2:4 (1 cement : 2 coarse sand : 4 graded stone aggregate 20 mm nominal size) in foundation of pump, DG set etc.including form work etc as required	Cum	2			
9	14.15.2	Supplying and laying of following size DWC HDPE pipe ISI marked along with all accessories like socket, bend, couplers etc. conforming to IS 14930, part II complete with fitting and cutting, jointing etc.in the existing trench , complete as required - 90 mm dia (OD90 mm & ID - 76 mm nominal)	Mtrs	160			
10	NPSR 4	Supplying new Bracket (hot dip galvanized as per ASTM A123) suitable for the existing pole and the light fixture in item no.3. Colour and all as directed by the Engineer-in-charge.	Nos	15			
11	NPSR 5	Fixing of the above Bracket with the light fixture	Mtrs.	15			
12	NPSR 6	Supplying and fixing of 20mm dia 700 mm long (62mm 75mm for curved portion) The bolts have 2 nos Nuts and Washers, 50mm PVC pipe for cable entry.	Nos.	32			

13	NPSR 7	Supply of 3 Core X1.5 Sqmm PVC Sheathed cable for Light fixtures	Mtrs	200			
14	NPSR 8	Supply of 4 x 16sqmm PVC armored, Aluminium under ground cable.	Mtrs	160			
15	NPSR 9	Laying of 4 x 16sqmm PVC armored, aluminium along the Bridge with proper clamping,etc	Mtrs	160			
16	NPSR 10	Making End termination 3 core X 1.5 sq mm. for the poles	Nos	8			
17	NPSR 11	Supply and fixing of VERTICAL THREE PHASE DISTRUBUTION BOARDMODULE TYPE WITH IP44 PROTECTION 12 way TPMCB sheet Steel distribution boards Hush type I surface type fitted With Bus bars and neutral links with single I three Phase MCB outgoing and separate 4 PROTECTION 12way TPMCB sheet Steel distribution boards Hush type I surface type fitted With Bus bars and neutral links with single I three Phase MCB outgoing and separate 4 way provisions for accommodating one no.4 pole Incoming MCB isolator and another separate 4 way provision for ccommodating on eno.4 pole incoming MCB . Isolator and another Separate 4 way provision for accommodating on end.4 pole ELCB/RCD with label holder and provisions for taking up cable for size not less the 35 Sq mm (seperate provision shall be given for mounting)	Nos.	1			
18	NPSR 12	Supply of 4 x 25 sqmm PVC armored, Aluminium under ground cable.	Mtrs.	50			
19	NPSR 13	Painting of the Existing Pole with Pu paint two or more coate over a priming coat as per manufacture specification. The rate inclusive of removing old paint, rust etc., using sand paper and preparing smooth surface for painting.	Nos.	15			

This NIT contains 19 items and approved for an amount of Rs. 11,85,900/-.
(Rupees eleven lakhs eighty five thousand and nine hundred only)

**CHIEF EXECUTIVE OFFICER
PSCDL**

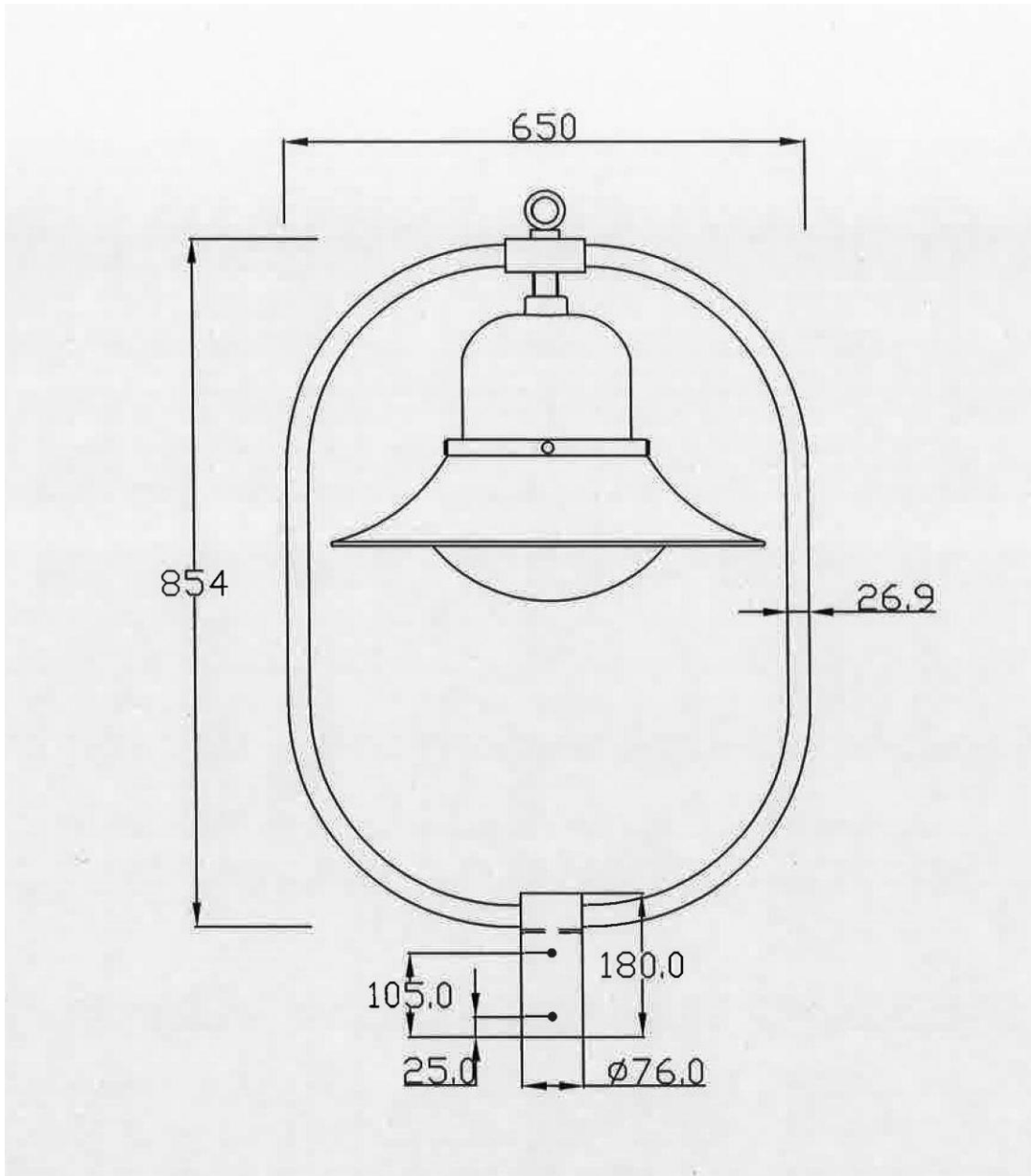

POST TOP WITH BRACKET – (ITEM NO.1)

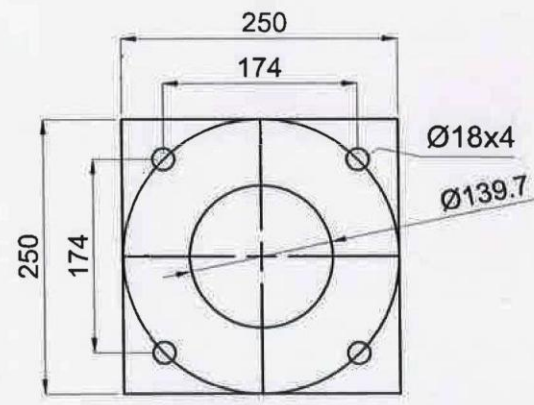
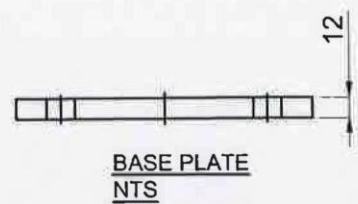
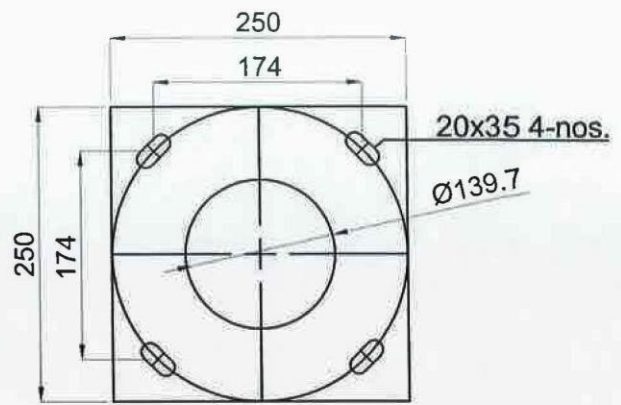
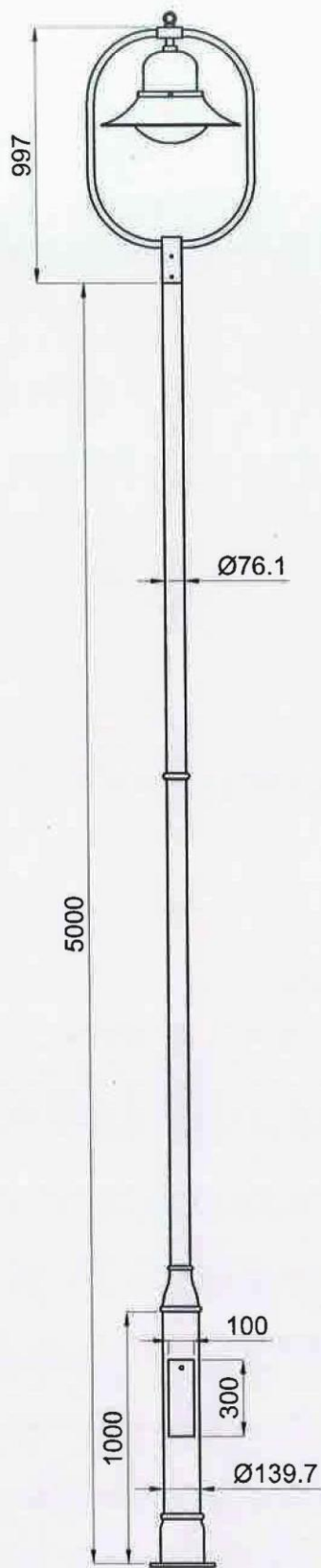

BASE PLATE TEMPLATE
NTS

POLE BLENHEIM 5M WITH VALE POST TOP – (ITEM NO.2)



LED LANTERN – (ITEM NO.3)

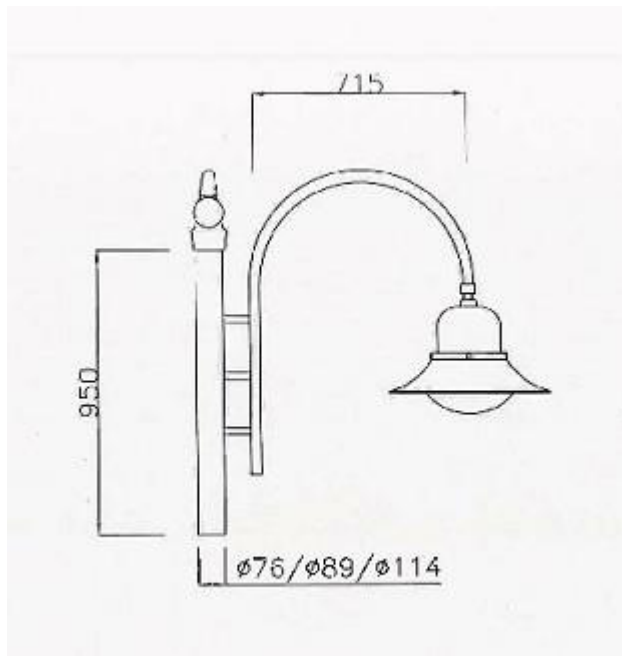

CASCADE BRACKET 0.7M SOH WITH VALE – (ITEM NO.10)